

## THE DIFFERENCE



# IS IN THE DOME

## Extend air filter life with the engine precleaner trusted by OEMs

Engine filter life is directly related to the amount of debris ingested through an engine's air intake. Installing a Sy-Klone Series 9000 Air Precleaner as the first stage of an engine air intake system prevents the majority of heavier-than-air particles from entering the system. This results in longer engine air filter life, more efficient engine performance, and decreased maintenance expenses.

## Minimize Dust, Maximize Engine Protection

- Extends engine air filter life, which increases uptime
- Handles wide variety of mixed debris, including mud, snow, rain, leaves, sawdust, chaff, and dust
- Unlike many of its competitors, Series 9000 works well at high altitudes and in snow
- Lowers cost per operating hour by reducing parts, labor, and downtime by reducing filter changes and downtime
- Easy to install - adaption kits and parts to fit a variety of machines
- Rugged, engineered polymer construction gives the strength of steel (without the corrosion) at the cost of plastic; the opaque material reduces glare, minimizing visual safety concerns

# Series 9000<sup>®</sup> EJECTIVE ENGINE AIR PRECLEANER

## How it Works: The “Sy-Klone Effect”

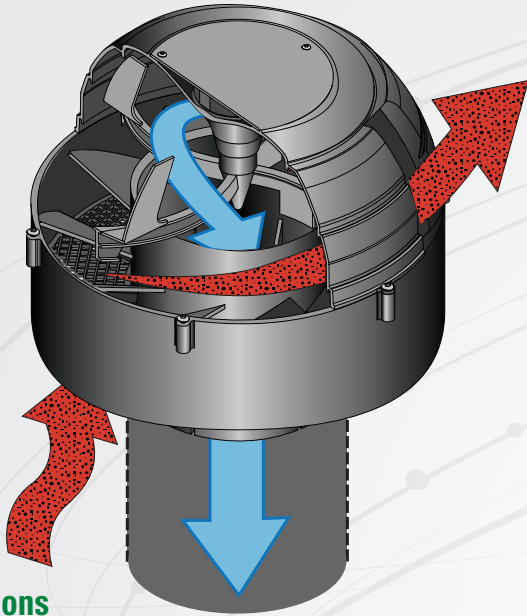

1. Dirty air enters the underside of the dome through screened louvers, which prevents clogging by blocking large debris from entering the unit
2. Curved blades direct air through the system, creating a “Sy-Klone”, pushing dirt and debris against the sidewalls of the dome
3. Strakes move heavier-than-air debris towards the ejection slot, where dirt and dust are ejected into the outside environment
4. Clean air, free from dirt and debris, continues to swirl down into the engine air inlet pipe

### Product Specifications

**Mounting:** Mounts on all vertical and horizontal air cleaner housings, on all machines, replacing those with rain caps, tube body systems or internal pre-cleaners

**Construction:** Engineered polymer is rugged and gives the strength of metal with the weight of plastic

**Bearings:** Patented, sealed bearing cavity protects bearings from debris and moisture, preventing corrosion. Grease concentration of 20% instead of the typically-used 10-15% concentration allows the Series 9000 to operate in extreme cold weather, down to -40½°F

**Maintenance:** Self-cleaning and routine maintenance-free, as no debris is trapped within the pre-cleaner

Model Number	Airflow Range in CFM ( <i>m<sup>3</sup>/min</i> )	Minimum Hood Clearance in inches ( <i>mm</i> )	Precleaner Outlet ID in inches ( <i>mm</i> )
9000	10-50 ( <i>0.28-1.42</i> )	2 ( <i>50.8</i> )	2.015 ( <i>51.18</i> )
9000R	50-120 ( <i>1.42-3.40</i> )	3 ( <i>76.2</i> )	3.021 ( <i>76.73</i> )
9001	100-275 ( <i>2.83-7.79</i> )	4 ( <i>101.6</i> )	4.031 ( <i>102.38</i> )
9001R	275-350 ( <i>7.79-9.91</i> )	4 ( <i>101.6</i> )	4.031 ( <i>102.38</i> )
9005	350-500 ( <i>9.91-14.16</i> )	5 ( <i>127.0</i> )	5.03 ( <i>127.29</i> )
9002	500-650 ( <i>14.16-18.41</i> )	6 ( <i>152.4</i> )	6.04 ( <i>153.74</i> )
9002R	650-800 ( <i>18.41-22.65</i> )	6 ( <i>152.4</i> )	6.04 ( <i>153.74</i> )
9003	800-1150 ( <i>22.65-32.56</i> )	8 ( <i>203.2</i> )	8.064 ( <i>204.77</i> )
9004	1150-1400 ( <i>32.56-39.64</i> )	8 ( <i>203.2</i> )	8.064 ( <i>204.77</i> )

CFM = Cubic Feet per Minute. m<sup>3</sup>/m = meters cubed per minute. Select model based on the CFM (m<sup>3</sup>/min) airflow requirements, not air inlet size. Use adaptation to fit; see Sy-Klone.com for options.

